

K.S.R.M. COLLEGE OF ENGINEERING (AUTONOMOUS), KADAPA
B. Tech. II Sem. (R18) Supplementary Examinations of March – 2021
SUB: Basic Electrical Engineering (CE & ME)

Time: 3 Hours

Max. Marks: 70

Answer any FIVE Questions choosing one question from each unit.
All questions carry Equal Marks.

UNIT – I

1. (a) Explain about various types of voltage and current sources. 7M
 (b) In the circuit, If three inductors of 5 Henry, 10 Henry and 15 Henry are connected in series then determine equivalent inductance of the circuit. 7M

(OR)

2. (a) Explain Kirchoff's Current and Voltage law 7M
 (b) Determine the magnitude of total current and current in each element if $R_1=10$ ohms, $R_2=20$ ohms and $V=50$ V 7M

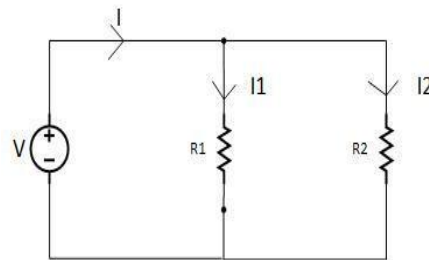
**UNIT – II**

3. (a) With a neat schematic, explain the principle of generation of alternating voltage. 7M
 (b) Determine the instantaneous value, peak value, RMS value, average value, form factor and peak factor of a signal of the form $V(t)=V_m \cos(\theta t + \omega)$. 7M

(OR)

4. (a) Explain the terms 'reactance' and 'impedance' with suitable examples. 7M
 (b) A coil when connected to 200V, 50Hz supply takes a current of 10A and dissipates 1200W. Find the resistance & reactance of the coil & also find real power and reactive power. 7M

UNIT – III

5. (a) Explain the constructional details of DC Generator with neat sketch. 7M
 (b) A 4 pole, wave-wound DC generator has 50 slots and 24 conductors / slot. The flux/pole is 10mWb. Determine the induced emf in the armature if it is rotating at 600 rpm. 7M

(OR)

6. (a) Explain the principle of operation of a DC motor. 7M
 (b) Explain the different types of DC motors and Mention their applications. 7M

UNIT – IV

7. (a) Derive the emf equation of a single phase transformer. 7M
 (b) The primary winding of a single phase transformer is connected to 220V, 50Hz supply. The secondary winding has 2000 turns. if the maximum value of the core flux is 0.003 Wb, determine i) the number of turns on primary winding and ii) the secondary induced voltage. 7M

(OR)

8. (a) Explain clearly the rotating magnetic field produced in the air gap of a 3 ϕ induction motor? 7M
(b) A 3 ϕ induction motor, 8 pole, 60Hz has a slip of 3% at full load. Find the synchronous speed and the frequency of rotor current at full load. 7M

UNIT-V

9. (a) Explain about Switch Fuse Unit (SFU) 7M
(b) Explain about Miniature Circuit Breaker (MCB) 7M
- (OR)**
10. (a) Explain about Wires and Cables in electrical installation. 7M
(b) Explain about Earthing system in electrical installation. 7M

K.S.R.M. COLLEGE OF ENGINEERING (AUTONOMOUS), KADAPA
B. Tech. II Sem. (R18) Supplementary Examinations of March – 2021
SUB: Basic Electrical Engineering (EEE)

Time: 3 Hours

Max. Marks: 70

Answer any FIVE Questions choosing one question from each unit.
All questions carry Equal Marks.

UNIT - I

1. (a) Define i)Active and Passive Elements ii)Unilateral and Bilateral Elements 4M
 (b) Calculate the equivalent Resistance between terminals a and b for the below circuit 10M

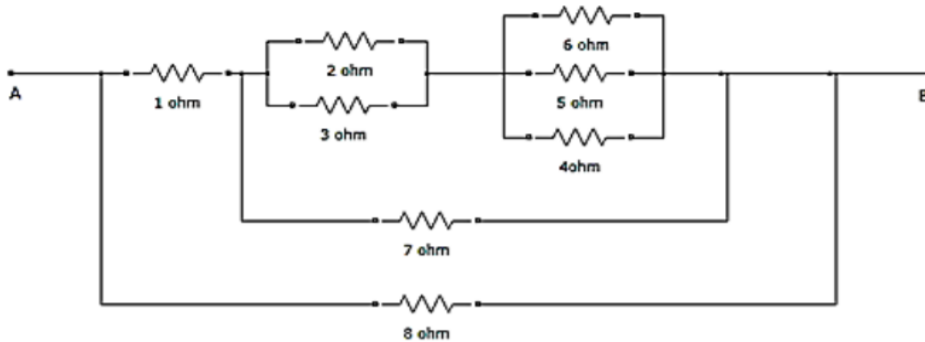

(OR)

2. (a) Solve this circuit using mesh analysis and find I_x and V_{R2} 10M

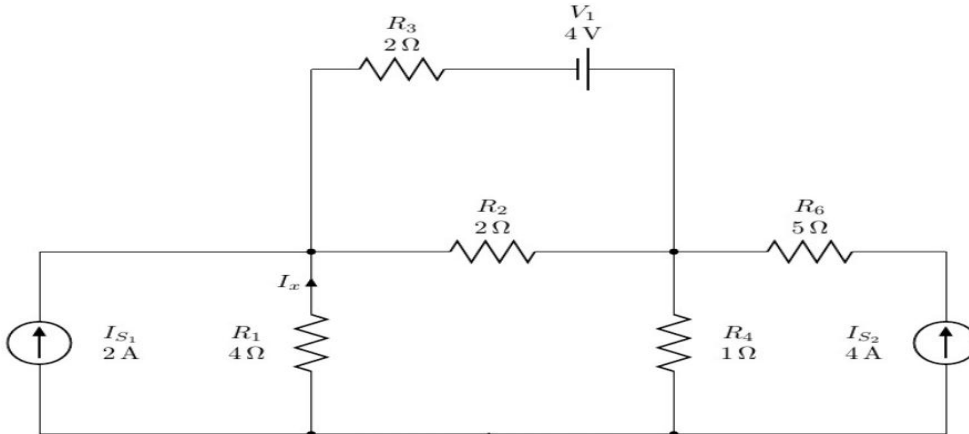

- (b) Derive the expression for an equivalent resistance if any two resistors R_1, R_2 are connected in parallel 4M

UNIT – II

3. (a) State and explain superposition theorem. 7M

(OR)

4. (a) State and explain Thevenin's theorem. 7M
 (b) For the circuit shown in fig.8.4 (a), find the current I_L through 6Ω resistor using 7M
 Thevenin's theorem.

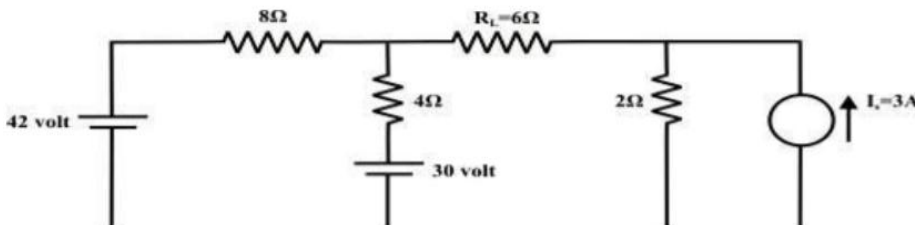

UNIT – III

5. (a) Define and determine the Average and RMS values of a sinusoidal voltage. 7M
 (b) A series circuit having a resistance and a capacitance draws a current of 2.4A from a 100V, 50Hz, single phase ac supply. The power consumed in the circuit is 80W. Determine the values of resistor and capacitor. 7M

(OR)

6. (a) Explain the significance of operator-j in alternating circuits. 4M
 (b) A coil having a resistance of 20 ohms and an inductance of 0.2 H is connected in series with a 50 μ F capacitor across a 250 V, 50 Hz supply. Calculate (i) the current (ii) the power (iii) the power factor (iv) the voltage across the coil and capacitor. Draw the phasor diagram showing the current and various voltages. 10M

UNIT – IV

7. (a) The two coils are connected in Parallel and they have self-inductance of 40mH and 10mH respectively. The total inductance of the circuit is found to be 50 mH. Determine: (i) The mutual inductance between the two coils. (ii) The coefficient of coupling 7M
 (b) State and explain the principle of duality and explain the graphical method to draw dual network? 7M

(OR)

8. (a) What is the analogy between electric and magnetic circuits? 7M
 (b) A steel ring of 180 cm mean diameter has a cross sectional area of 250mm² . Flux developed in the ring is 250 μ Wb when a 4000 turns coil carries certain current. Calculate (i) MMF required (ii) Reluctance (iii) Current in the coil. Assume relative permeability of steel is 1100 7M

UNIT-V

9. (a) Explain the following with an example a) Cut set matrix b) Bus incidence matrix c) Branch path incidence matrix d) basic loop incidence matrix 14M

(OR)

10. (a) What is complete incidence matrix? How is reduced incidence matrix obtained from it? Explain with suitable example. 7M
 (b) For the given Network diagram draw its tree and Co-Tree and evaluate the following terms
 (i) No of Links (ii) No. of Branches (iii) No. of Nodes

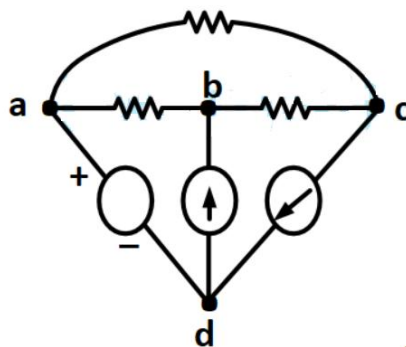

7M

Q.P. Code: 1805204

SET - 2

K.S.R.M. COLLEGE OF ENGINEERING (AUTONOMOUS), KADAPA
B. Tech. II Sem. (R18) Supplementary Examinations of March – 2021
SUB: Programming for Problem Solving (ECE & CSE)

Time: 3 Hours

Max. Marks: 70

Answer any FIVE Questions choosing one question from each unit.
All questions carry Equal Marks.

UNIT - I

1. (a) What is a Flowchart? What are the various symbols used while drawing the flowchart? 7M
(b) Write an algorithm to find the roots of given quadratic equation. 7M

(OR)

2. (a) Name the various kinds of data types are supported by C and explain about their memory requirements in detail. 7M
(b) Explain about Software Development life cycle in detail. 7M

UNIT – II

3. (a) Explain the following operators and illustrate it with an example each. 7M
(i) Logical OR (ii) Conditional operator (iii) Logical NOT (iv) Bitwise AND
(b) Explain about the Operator precedence and associativity rules in detail. 7M

(OR)

4. (a) Write a C program to illustrate switch statement. 7M
(b) Explain about the various loop constructs used in C language. 7M

UNIT – III

5. (a) Write a C program to implement linear search algorithm. 7M
(b) Write a C Program to sort given strings in descending order. 7M

(OR)

6. (a) In what way array is different from an ordinary variable? What conditions must be satisfied by the entire elements of any given Array? 6M
(b) Explain about the following string handling functions along with their syntax: 8M
i) strcpy() ii) strcmp() iii) strncpy() iv) strlen()

UNIT – IV

7. (a) What is recursion? Write a C program to find GCD of the given two numbers using recursive function. 7M
(b) Write a 'C' program to illustrate the use of indirection operator '*' to access the value pointed by a pointer. 7M

(OR)

8. (a) Explain about Call-by-Value and Call-by-reference mechanisms with suitable examples. 7M
(b) Explain about the following storage classes along with suitable examples: 7M
i) Automatic ii) Register

UNIT-V

9. (a) Explain about the concept of nested structures in C language with suitable example program. 7M
(b) Explain about the different ways of passing an entire structure as an argument to a function with suitable example program. 7M

(OR)

10. (a) What are the differences between a structure and union? Illustrate with the help of a suitable example. 7M
(b) Explain about the array of structure variables with suitable example program. 7M

K.S.R.M. COLLEGE OF ENGINEERING (AUTONOMOUS), KADAPA
B. Tech. II Sem. (R18) Supplementary Examinations of March – 2021
SUB: Mathematics-II (Common to all Branches)

Time: 3 Hours

Max. Marks: 70

Answer any FIVE Questions choosing one question from each unit.

All questions carry Equal Marks.

UNIT - I

1. (a) Solve $\frac{dy}{dx} + y \tan x = y^3 \cos x$ 7 M
 (b) Solve $(xy^3 + y)dx + 2(x^2y^2 + x + y^4)dy = 0$ 7 M
 (OR)
 2. (a) Find the orthogonal trajectories of the hyperbolas Solve $xy = c$ 4 M
 (b) Uranium disintegrates at a rate proportional to the amount present at any instant. If M_1 and M_2 grams of uranium are present at times T_1 and T_2 respectively, show that the half-life of uranium is $\frac{(T_2 - T_1) \log 2}{\log(M_1 / M_2)}$ 10 M

UNIT - II

3. Solve the differential equation $(D-2)^2 y = 8(x^2 + e^{2x} + \sin 2x)$ 14 M
 (OR)
 4. Apply the Method of variation of parameters to solve $\frac{d^2y}{dx^2} + 4y = 4 \sec^2 2x$ 14 M

UNIT - III

5. (a) Find the Laplace Transform of the function $f(t) = e^{-3t} (2 \cos 5t - 3 \sin 5t)$ 6 M
 (b) Apply Convolution theorem find $L^{-1} \left(\frac{s^2}{(s^2 + 4)^2} \right)$ 8 M
 (OR)
 6. Solve the differential equation $\frac{d^2x}{dt^2} + 9x = \cos 2t$, if $x(0) = 1, x\left(\frac{\pi}{2}\right) = -1$ by using Laplace Transform Method 14 M

UNIT - IV

7. Evaluate $I = \int_0^1 \int_{x^2}^{2-x} xy \, dx dy$ by change order of integration 14 M
 (OR)
 8. (a) Calculate $\int_0^1 \int_0^{\sqrt{1-x^2}} \int_0^{\sqrt{1-x^2-y^2}} \frac{dz dy dx}{\sqrt{1-x^2-y^2-z^2}}$ by changing to spherical polar coordinates 7 M
 (b) Evaluate $\iiint (x+y+z) \, dx dy dz$ over the tetrahedron bounded by the planes $x=0, y=0, z=0$ and $x+y+z=1$. 7 M

UNIT-V

9. (a) Find the angle between the surfaces $x^2 + y^2 + z^2 = 9$ and $z = x^2 + y^2 - 3$, at the point $(2, -1, 2)$ 7 M
 (b) Find $\text{div } \vec{F}$ and $\text{curl } \vec{F}$, Where $\vec{F} = \text{grad}(x^3 + y^3 + z^3 - 3xyz)$ 7 M
 (OR)
 10. Verify Green's theorem for $\oint_C [(xy + y^2)dx + x^2 dy]$ where C is bounded by $y = x$ and $y = x^2$ 14 M

Q.P. Code: 1822202

SET - 2

K.S.R.M. COLLEGE OF ENGINEERING (AUTONOMOUS), KADAPA
B. Tech. II Sem. (R18) Supplementary Examinations of March – 2021
SUB: Engineering Physics (CE)

Time: 3 Hours

Max. Marks: 70

Answer any FIVE Questions choosing one question from each unit.
All questions carry Equal Marks.

UNIT - I

1. (a) Describe the formation of Newton's rings with necessary theory? 9M
(b) Explain how the refractive index of liquid is determined by forming Newton's rings? 5M

(OR)

2. (a) Describe Fraunhofer diffraction due to grating? 9M
(b) Distinguish between interference and diffraction? 5M

UNIT – II

3. (a) State the principle and explain the working of semiconductor laser with neat energy band diagram? 9M
(b) Explain the various excitation mechanisms? 5M

(OR)

4. (a) Describe the construction and working of Nd-YAG laser? 9M
(b) Write in detail about optical resonator? 5M

UNIT – III

5. (a) What are the Newton's laws and write their applications? 7M
(b) Explain velocity and acceleration in polar coordinates? 7M

(OR)

6. (a) Derive the formal solution of kinematical equations? 8M
(b) Explain motion of the particle in one dimension and several dimensions? 6M

UNIT – IV

7. (a) What is the rigid body and explain motion in the plane? 7M
(b) Derive the kinematics in a co-ordinate system rotating and translating in the plane? 7M

(OR)

8. (a) Explain the Euler's laws of motion? 7M
(b) Explain angular momentum about a point of a rigid body in planar motion? 7M

UNIT-V

9. (a) What are the assumptions and drawbacks of classical free electron theory? 7M
(b) Explain in detail about origin of energy bands in solids? 7M

(OR)

10. (a) Describe the direct and indirect band gap semiconductors? 7M
(b) Write in detail about drift and diffusion in semiconductor? 7M

K.S.R.M. COLLEGE OF ENGINEERING (AUTONOMOUS), KADAPA
B. Tech. II Sem. (R18) Supplementary Examinations of March – 2021
SUB: Engineering Physics (EEE)

Time: 3 Hours**Max. Marks: 70**

Answer any FIVE Questions choosing one question from each unit.
All questions carry Equal Marks.

UNIT - I

1. (a) Differentiate damped and forced vibrations with suitable example. Determine the amplitude of forced harmonic oscillator. 8M
(b) What is the principle of superposition of waves? Explain the different cases when two waves of same frequency is superposed linearly. 6M

(OR)

2. (a) Define simple harmonic motion. Derive the equation of simple harmonic motion. Discuss any four characteristics of SHM in detail. 10M
(b) Define resonance phenomena. Discuss the necessary conditions to produce resonance. 4M

UNIT – II

3. (a) Discuss the Fraunhofer diffraction due to single slit. Obtain the condition for principle maxima and minima in the intensity distribution of diffraction pattern. 10M
(b) Calculate the possible order of spectra with a plane transmission grating having 18,000 lines/inch when light of wavelength 4500 Å is used. 4M

(OR)

4. (a) How Newton's rings are formed. Draw a neat sketch of experimental set up and explain. Determine the wavelength of incident monochromatic light. 10M
(b) Discuss the interference in thin films by division of amplitude principle. 4M

UNIT – III

5. (a) Mention the advantage of four level laser system. Describe the construction and working of Nd-YAG solid state laser with a neat sketch of energy level diagram. Draw its merits and demerits. 10M
(b) Discuss the importance of population inversion in laser systems. 4M

(OR)

6. (a) Explain the construction and working of semiconductor p-n junction diode laser. Mention the merits and demerits. 10M
(b) Discuss the conditions for dominated stimulated emission process in the laser materials. 4M

UNIT – IV

7. (a) Describe uncertain theory based on quantum mechanics principles. 4M
(b) Show that the solution of Schrodinger's time independent wave equation for a particle in an infinite potential well leads to the concept of quantization of energy levels. Discuss its wave functions and energy levels for the ground state and the two excited states. 10M

(OR)

8. (a) Discuss the significance of wave function. 4M
(b) Derive the time-dependent and time-independent Schrodinger wave equations. 10M

UNIT-V

9. (a) With the mathematical formulation, explain the motion of a charged particle in a periodic potential. How this mathematical formulation does proved the band theory of solids. 8M
(b) Define average drift velocity of charged particles in metals. Obtain an expression for the drift velocity of the particles. 6M

(OR)

10. (a) Explain the significance of Fermi energy level in semiconductors. Discuss the dependence of Fermi level with temperature and doping concentration. 10M
(b) Differentiate direct and indirect band gap semiconductors with examples. 4M

K.S.R.M. COLLEGE OF ENGINEERING (AUTONOMOUS), KADAPA**B. Tech. II Sem. (R18) Supplementary Examinations of March – 2021*****SUB: Engineering Physics (ME)*****Time: 3 Hours****Max. Marks: 70****Answer any FIVE Questions choosing one question from each unit.****All questions carry Equal Marks.****UNIT - I**

1. (a) How Newton's rings are formed? Draw a neat diagram showing the formation rings as well as the experimental set up. Obtain the condition for bright and dark fringes. Determine the wavelength of sodium light using Newton's ring experiment. 10M
- (b) In a Newton's rings experiment, the diameter of the 15th ring was found to be 0.59 cm and that of the 5th ring was 0.336 cm. If the radius of the plane-convex lens is 100 cm. calculate the wavelength of light used. What happens to ring diameter if air film is replaced with liquid of refractive index 1.5. 4M

(OR)

2. (a) Describe the interference of light using Young's double slit experiment. Derive the expression for fringe width. A plane diffraction grating has the value of 25.28° as the position of the third order maximum for $\lambda = 2.4 \times 10^{-4}$ cm. calculate the diffraction grating (d). 10M
- (b) Explain the Interference in thin film by reflection based on division of amplitude. 4M

UNIT – II

3. (a) Give an example of a solid state laser working with four level pumping scheme. Discuss the construction and working of this laser with neat sketch of energy level diagram. 10M
- (b) Discuss the different excitation mechanisms in laser. 4M

(OR)

4. (a) How semiconductor diode lasers are made? Give some examples of materials used for semiconductor diode laser. Describe with energy band diagram the construction and working of semiconductor diode laser. Mention the uses of diode lasers. 10M
- (b) Explain the applications of lasers in medical field. 4M

UNIT – III

5. (a) What is meant by harmonic oscillator? Discuss the Simple harmonic motion of a Mass spring system and evaluate the frequency and its time period for horizontal and vertical vibrations. 10M
- (b) Describe the q-factor of a forced electrical oscillator. 4M

(OR)

6. (a) Describe the Damped harmonic oscillator with an example. Determine the time period and amplitude of damped harmonic oscillations for heavy, critical and light damping conditions. 10M
- (b) Discuss the importance of Mechanical impedance 4M

UNIT – IV

7. (a) Discuss the Transmission of waves at a boundary. Draw some conclusions. 7M
- (b) Define Longitudinal waves with examples and Derive the wave equation for longitudinal waves. 7M

(OR)

8. (a) What is Impedance matching in wave motion? How the impedance mismatch influences the propagation of wave. 6M

- (b) Discuss the production of Transverse waves with an example and derive the wave equation for it. 8M

UNIT-V

9. (a) What are the special features of classical free electron theory of metals? Derive an expression for the electrical conductivity based on the Drude and Lorentz model. Discuss the merits and demerits of the free electron theory. 10M
- (b) Discuss the significance of Fermi energy level in semiconductors. Find the temperature at which there is 1% probability that a state with energy 2 eV is occupied. Given that Fermi energy is 1.5 eV. 4M

(OR)

10. (a) Differentiate the p- and n-type semiconductors with the help of energy band diagram. Explain the formation of depletion region in a p-n junction diode. 8M
- (b) Differentiate direct and indirect band gap semiconductors using suitable energy level diagrams along with examples 6M

K.S.R.M. COLLEGE OF ENGINEERING (AUTONOMOUS), KADAPA
B. Tech. II Sem. (R18) Supplementary Examinations of March – 2021
SUB: Engineering Chemistry (ECE & CSE)

Time: 3 Hours**Max. Marks: 70****Answer any FIVE Questions choosing one question from each unit.****All questions carry Equal Marks.****UNIT - I**

1. (a) Apply Schrodinger wave equation for a particle in one dimension box. 7 M
(b) Explain the molecular orbital diagram of diatomic molecules with suitable example 7 M

(OR)

2. (a) Explain the crystal field theory and write notes on crystal field splitting of energy levels in tetrahedral complexes. 7 M
(b) Define doping. Illustrate the types of doping with suitable examples. 7 M

UNIT – II

3. (a) Explain in detail the variations of s, p, d, f orbital energies of atoms in the periodic table. 7 M
(b) Write short notes on (i) Effective nuclear charge (ii) Electron affinity 7 M

(OR)

4. (a) Explain about hard and soft acids and bases with examples. 7 M
(b) Write short notes on (i) co-ordination number and electronic configuration. 7 M

UNIT – III

5. (a) Explain in detail about the boiler troubles. 14M

(OR)

6. (a) Explain about electrochemical wet corrosion with an example. 7 M
(b) Describe the various factors influencing corrosion based on nature of the metal. 7 M

UNIT – IV

7. (a) Discuss about vibrational and rotational spectra of diatomic molecules. 14M

(OR)

8. (a) Explain the Franck-Condon Principle 7 M
(b) Illustrate the various electronic excitations in electronic spectroscopy. 7 M

UNIT-V

9. (a) Explain the conformational analysis of cyclohexane. 7 M
(b) Describe diastereomers and enantiomers with examples. 7 M

(OR)

10. (a) Explain the mechanism of SN² substitution reaction with suitable examples. 7 M
(b) Write the addition reactions involving C=O by Grignard reagent. 7 M

K.S.R.M. COLLEGE OF ENGINEERING (AUTONOMOUS), KADAPA
B. Tech. II Sem. (R18) Supplementary Examinations of March – 2021
SUB: English - I (ECE & CSE)

Time: 3 Hours

Max. Marks: 70

Answer any FIVE Questions.
All questions carry Equal Marks.

1. Correct the following sentences if necessary. 14M
- (i) I came to office by foot.
 - (ii) Our class is in the second floor
 - (iii) I drank tea just now.
 - (iv) My cousin brother is a doctor.
 - (v) I go to the school every day.
 - (vi) My friend is an teacher.
 - (vii) His son-in-laws have come home.
 - (viii) I prefer tea than coffee.
 - (ix) You have to add up Hyderabad in the list of developed cities.
 - (x) He has created an all time record.
 - (xi) I am having four brothers.
 - (xii) My self I am Sudha Rani.
 - (xiii) arizona is in america
 - (xiv) The woman which works here is from Delhi.
 - (xv) She is married with a dentist.
2. (a) Give synonyms of the following words. 3M
- (i) Courage
 - (ii) Timid
 - (iii) Ferocious
- (b) Give antonyms of the following words. 3M
- (i) Benevolent
 - (ii) Development
 - (iii) Freedom
- (c) Write a short note on the word formation methods along with three examples each. 8M
3. **Rewrite the sentences as directed.** 14M
- (i) I am a teacher and I teach English. (change it into a simple sentence)
 - (ii) In spite of poverty, she paid the fee.(change it into a complex sentence)
 - (iii) The lady who was our tour guide is an American. (change it into compound sentence)
 - (iv) He confessed his illegal act. (change it into complex sentence)
- Rewrite the following sentences to correct the misplaced modifiers:**
- (v) She served sandwiches to the children on paper plates.
 - (vi) She saw a puppy and a kitten on the way to the store.
- Correct the sentences from redundancy:**
- (vii) Ravi returned back from America last week.
 - (viii) It is usually his custom to visit the houses of the affluent rich.
 - (ix) In my opinion I am correct in this matter.
 - (x) Two companies collaborated together in this venture.
- Change the sentences as directed.**
- (xi) Very few countries in the world are as large as China. (change into superlative)
 - (xii) Vivekananda was one of the most popular Indian saints. (change into positive)
 - (xiii) The Pacific ocean is deeper than all other oceans.(change it into superlative)
 - (xiv) The rose is the most beautiful flower in the world.(change it into positive degree)
4. (a) Organize the following sentences into a meaningful paragraph. 5M
- a) Summary is a shortened version of a letter, a report, an article, a chapter or a book,

written in our own words.

- b) You should read through the passage to find its theme, or what the writer is talking about.
- c) Summary writing needs the use of many skills, namely reading, understanding and analyzing what is read, selecting important points and making notes, and paraphrasing the original passage clearly and briefly in our own words.
- d) See how the theme is developed and write down the main points in the form of numbered notes.
- e) The theme, or topic, would be the title of your summary.
- f) Summaries are useful when we do not have time to read the original texts.
- g) Use the notes above to write the first draft of your summary.
- h) The right methodology for writing the summary is as follows.

(b) **Use the following idioms and phrases in your own sentences.** 5M

- (i) Bitter pill (ii) look upon (iii) add insult to the injury
- (iv) Devil's advocate (v) Cry over spilt milk

(c) Fill in the blanks with suitable article. 4M

- (i) Bring --- umbrella in my closet if it looks like rain.
- (ii) Did you get -- visa you applied for?
- (iii) I have seen-----one rupee note here.
- (iv) We are all engineers with ---common belief.

5. (a) **Write an essay on 'Growing up in Poverty' in 350 words.** 7M

(b) Write a précis of the following essay. 7M

Unidentified Flying Object (or "UFO") is a term commonly used to describe lights or shapes in the sky. It was first coined by the United States Air Force in 1952 to describe sightings of mysterious objects in the sky that could not be explained even after careful investigation. Nowadays UFOs are spotted frequently, and feature in numerous movies and TV shows. Another popular name for such an object is, "Flying Saucer," in reference to the round shape of many UFOs. The first widely publicized UFO sighting was in 1947, by a pilot called Kenneth Arnold. Following this event, public sightings of UFOs increased dramatically. Movies and TV shows began featuring visitors from outer space, arriving on earth in flying saucers. With the popularity of these images, many people claimed to have seen lights in the sky. Some experts believe that people simply think they see UFOs because of the influence of TV and movies.

However, experts estimate that as little as 5% of these sightings could be called "unidentified." Usually these lights are made by aircraft, satellites, or weather balloons. Top secret air force activities during the Cold War may have been responsible for many of the UFO sightings in America and Europe. Although not actually aliens, the secretive nature of these flying objects is definitely unidentified. Another popular idea concerning UFOs concerns the role of world governments. Specifically, people believe that the US government has discovered alien life and operates a "cover-up" to hide the truth from the public. The most widely believed cover-up is that of the Roswell Incident. In July, 1947, a UFO supposedly landed in Roswell, New Mexico, and was examined and hidden by government agents. There have been many investigations into the Roswell incident, however, these reports always claim that no such event occurred.

6. (a) Read the following and answer the questions given below.

8M

Mrs. Wilson and Mrs. Smith are sisters. Mrs. Wilson lives in a house in Duncan and Mrs. Smith lives in a condominium in Victoria. One day Mrs. Wilson visited her sister. When her sister answered the door, Mrs. Wilson saw tears in her eyes. "What's the matter?" she asked. Mrs. Smith said "My cat Sammy died last night and I have no place to bury him".

She began to cry again. Mrs. Wilson was very sad because she knew her sister loved the cat very much. Suddenly Mrs. Wilson said "I can bury your cat in my garden in Duncan and you can come and visit him sometimes." Mrs. Smith stopped crying and the two sisters had tea together and a nice visit.

It was now five o'clock and Mrs. Wilson said it was time for her to go home. She put on her hat, coat and gloves and Mrs. Smith put the dead Sammy into a shopping bag. Mrs. Wilson took the shopping bag and walked to the bus stop. She waited a long time for the bus so she bought a newspaper. When the bus arrived, she got on the bus, sat down and put the shopping bag on the floor beside her feet. She then began to read the newspaper. When the bus arrived at her bus stop, she got off the bus and walked for about two minutes. Suddenly she remembered she had left the shopping bag on the bus.

1. Where does Mrs. Smith live?

- A) In a condominium in Duncan B) In a condominium in Victoria
C) In a house in Duncan

2. Why is Mrs. Smith upset?

- A) Because her sister came to see her cat. B) Because her cat died
C) Because Mrs. Wilson was sad

3. What did Mrs. Wilson do?

- A) Take the cat with her on the bus B) Put her gloves in the shopping bag
C) Prepare dinner for her sister

4. Who did Sammy the cat live with?

- A) Mrs. Wilson B) Mrs. Smith C) Mr. Wilson and Mrs. Smith

5. What time did Mrs. Wilson go home?

- A) When the bus arrived B) At 5PM C) After she walked for two minutes

6. How did Mrs. Wilson go home?

- A) Walked for two minutes before she caught the bus
B) Read a newspaper on the bus C) Took a bus

7. What did Mrs. Wilson forget?

- A) The newspaper B) Her handbag C) The shopping bag

8. Where did Sammy die?

- A) In Mrs. Smith's house in Duncan B) In Mrs. Wilson's garden C) In Victoria

(b) Identify the redundancy in the following sentences and rewrite them.

6M

(i) If all of us cooperate together, we will succeed.

(ii) The accused was guilty of false misstatement.

(iii) I am enclosing herewith with my bio-data.

(iv) The three brothers had nothing common among each other.

(v) It was a common consensus to watch a movie now.

(vi) All of us returned back from London today.

7. (a) Fill in the blanks with suitable verb forms of the words in the brackets.

7M

(i) ----- (do) he play tennis?

(ii) You----- (learn) English now.

(iii) I ----- (see) a movie yesterday.

(iv) I ----- (gone) to Brazil recently.

(v) Many writers ----- (write) on current affairs these days.

(vi) You ----- (wait) for her when her plane arrives tonight.

(vii) You ----- (study) English before you moved to New York.

- (b) Fill in the blanks with suitable prepositions. 7M
- (i) We live- --London.
 - (ii) Would you like -----go to cinema tonight.
 - (iii) There is a bridge-----the river.
 - (iv) Who is -----the picture.
 - (v) We are going-----holiday next week.
 - (vi) I haven't been -----countryside -----December.
 - (vii) My house is situated-----the cinema hall.

8. (a) **Write an essay on 'Students should not be allowed to play PUBG' 350 words.** 7M

(b) Write a précis of the following essay. 7M

The essay is a commonly assigned form of writing that every student will encounter while in academia. Therefore, it is wise for the student to become capable and comfortable with this type of writing early on in her training.

Essays can be a rewarding and challenging type of writing and are often assigned either to be done in class, which requires previous planning and practice (and a bit of creativity) on the part of the student, or as homework, which likewise demands a certain amount of preparation. Many poorly crafted essays have been produced on account of a lack of preparation and confidence. However, students can avoid the discomfort often associated with essay writing by understanding some common genres.

Though the word *essay* has come to be understood as a type of writing in Modern English, its origins provide us with some useful insights. The word comes into the English language through the French influence on Middle English; tracing it back further, we find that the French form of the word comes from the Latin verb *exigere*, which means "to examine, test, or (literally) to drive out." Through the excavation of this ancient word, we are able to unearth the essence of the academic essay: to encourage students to test or examine their ideas concerning a particular topic.

Essays are shorter pieces of writing that often require the student to hone a number of skills such as close reading, analysis, comparison and contrast, persuasion, conciseness, clarity, and exposition. As is evidenced by this list of attributes, there is much to be gained by the student who strives to succeed at essay writing.

The purpose of an essay is to encourage students to develop ideas and concepts in their writing with the direction of little more than their own thoughts (it may be helpful to view the essay as the converse of a research paper). Therefore, essays are (by nature) concise and require clarity in purpose and direction. This means that there is no room for the student's thoughts to wander or stray from his or her purpose; the writing must be deliberate and interesting.